



**SPLIT TYPE
ROOM AIR CONDITIONER**
CEILING WALL type

SERVICE MANUAL

Models	Indoor unit	Outdoor unit
	AWH24LBAJ	AOH24LMAL
	AWH30LBAJ	AOH30LMAL



CONTENTS

SPECIFICATIONS	1
OUTLINE AND DIMENSIONS	3
REFRIGERANT SYSTEM DIAGRAM	4
ERROR CONTENTS	5
CIRCUIT DIAGRAM	6
INDOOR PRINTED CIRCUIT BOARD CIRCUIT DIAGRAM	7
OUTDOOR PRINTED CIRCUIT BOARD CIRCUIT DIAGRAM ..	8
DISASSEMBLY ILLUSTRATION	12
PARTS LIST	23
STANDARD ACCESSORIES	25

SPECIFICATIONS

TYPE		COOL & HEAT	COOL & HEAT
INDOOR UNIT		AWH24LBAJ	AWH30LBAJ
OUTDOOR UNIT		AOH24LMAL	AOH30LMAL
COOLING CAPACITY	(kW)	6.8	8.0
HEATING CAPACITY	(kW)	7.0	8.5

ELECTRICAL DATA

POWER SOURCE	(V)	230		
FREQUENCY	(Hz)	50		
RUNNING CURRENT	(A)	COOLING	9.3	13.3
		HEATING	8.5	12.3
INPUT WATTS	(kW)	COOLING	2.12	3.04
		HEATING	1.94	2.81
E.E.R.	(kW/kW)	COOLING	3.21	2.68
		HEATING	3.61	3.02
MOISTURE REMOVAL	(ℓ/hr)	3.0	3.6	
AIR CIRCULATION-Hi	(m ³ /hr)	1,050	1,050	

COMPRESSOR

TYPE		Hermetic type, Inverter, 4 poles, Three phase, DC motor, Twin Rotary
DISCRIMINATION		TNB220FPCM9
REFRIGERANT	R410A (g)	1,850

FAN MOTOR

POWER SOURCE	(V)	230	
INDOOR UNIT	DISCRIMINATION	MFD-36JO	
	HI-SPEED	(r.p.m.)	1,450
	MED-SPEED	(r.p.m.)	1,280
	LO-SPEED	(r.p.m.)	1,180
	QUIET	(r.p.m.)	1,080
OUTDOOR UNIT	DISCRIMINATION	MFB-30NTAT	
		(r.p.m.)	730

DIMENSIONS

INDOOR UNIT	H x W x D	(mm)	270 x 1,150 x 285
OUTDOOR UNIT	H x W x D	(mm)	900 x 900 x 350

WEIGHT

INDOOR UNIT	GROSS / NET	(kg)	20 / 16
OUTDOOR UNIT	GROSS / NET	(kg)	78 / 70

TYPE	COOL & HEAT	COOL & HEAT
INDOOR UNIT	AWH24LBAJ	AWH30LBAJ
OUTDOOR UNIT	AOH24LMAL	AOH30LMAL

NOISE LEVEL

INDOOR UNIT	HI-SPEED (dB)	47
	MED-SPEED (dB)	43
	LO-SPEED (dB)	40
	QUIET-SPEED (dB)	37
OUTDOOR UNIT	(dB)	52

REFRIGERANT CHARGE (R410A)

FULL CHARGE AMOUNT	PIPE LENGTH	10 m (33 ft.)	1,850 g (65.1 oz)
		15 m (49 ft.)	2,100 g (73.9 oz)
		20 m (66 ft.)	2,350 g (82.7 oz)
		25 m (82 ft.)	2,600 g (91.7 oz)
ADDITIONAL REFRIGERANT		50 g / m (1.76 oz / 3.3 ft.) (over 10 m)	

OUTLINE AND DIMENSIONS

Models : AWH24LBAJ
AWH30LBAJ

Unit : mm

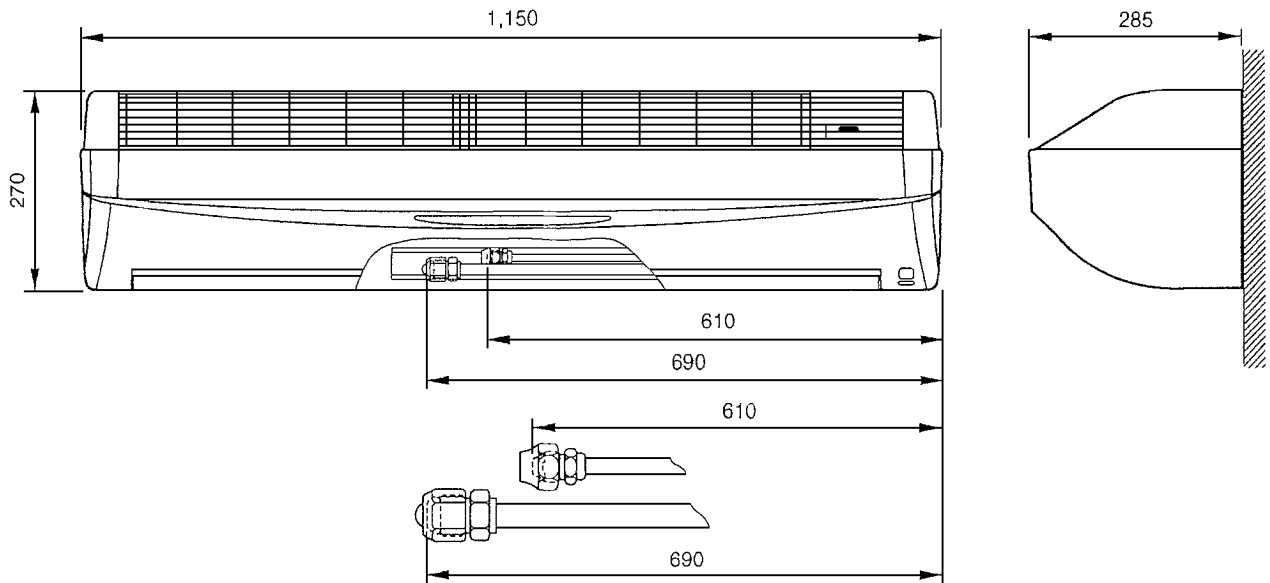

Models : AOH24LMAL
AOH30LMAL

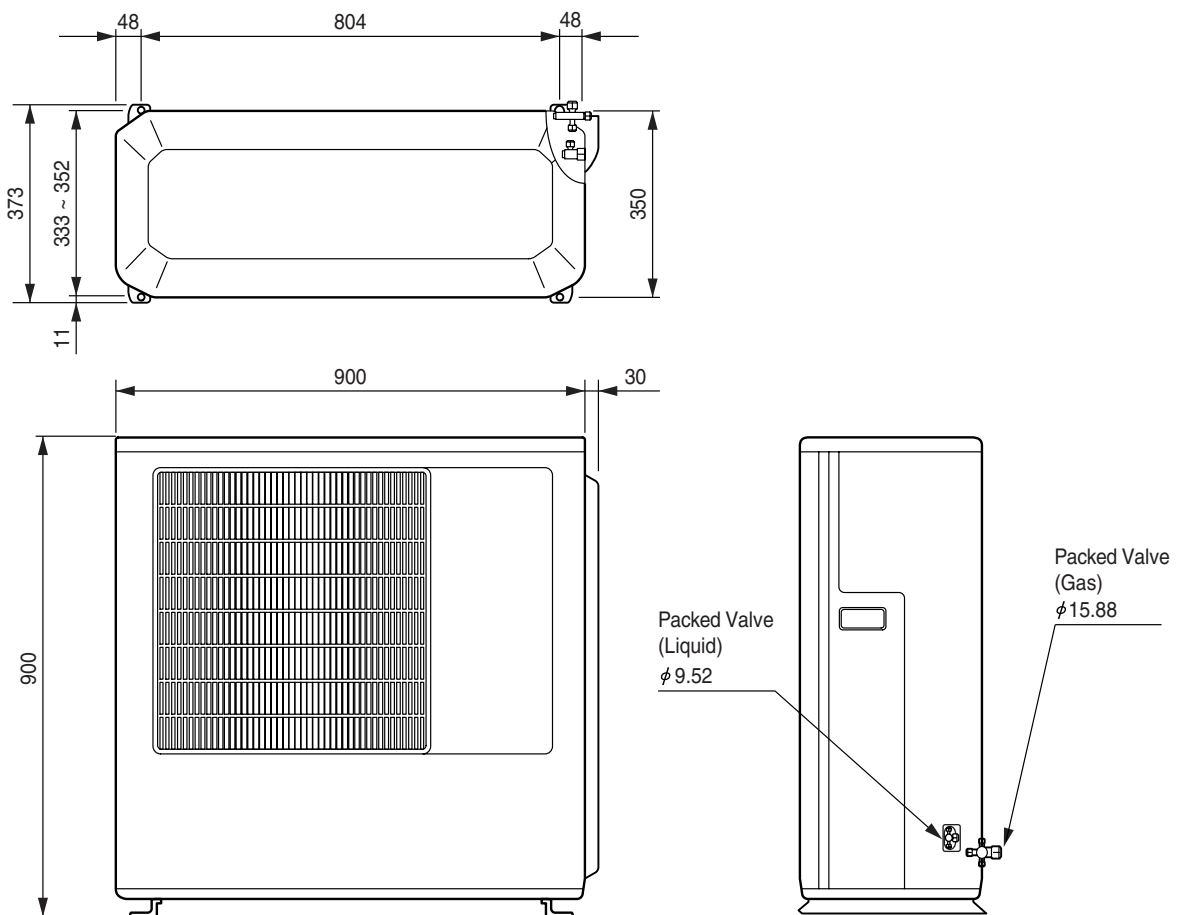

REFRIGERANT SYSTEM DIAGRAM

Models : AWH24LBAJ / AOH24LMAL
AWH30LBAJ / AOH30LMAL

OUTDOOR UNIT

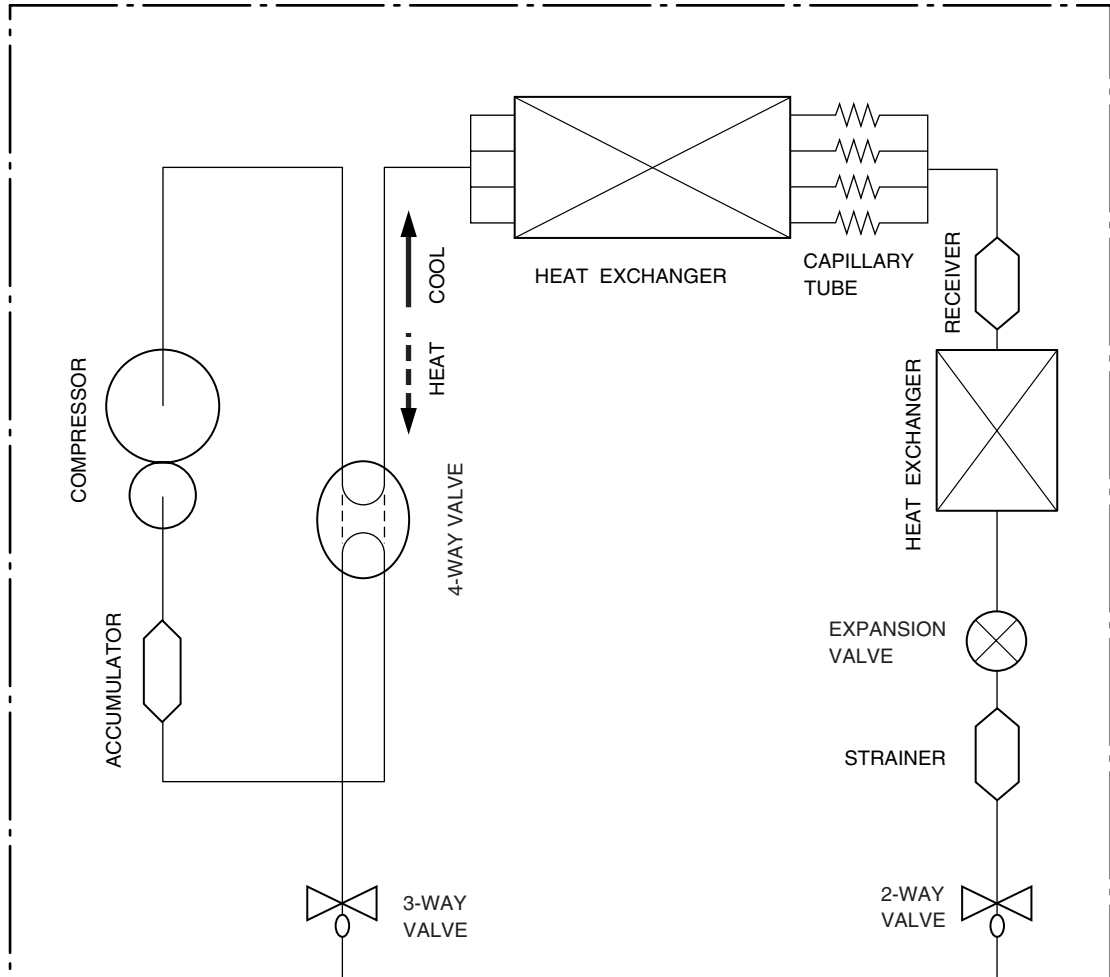

INDOOR UNIT

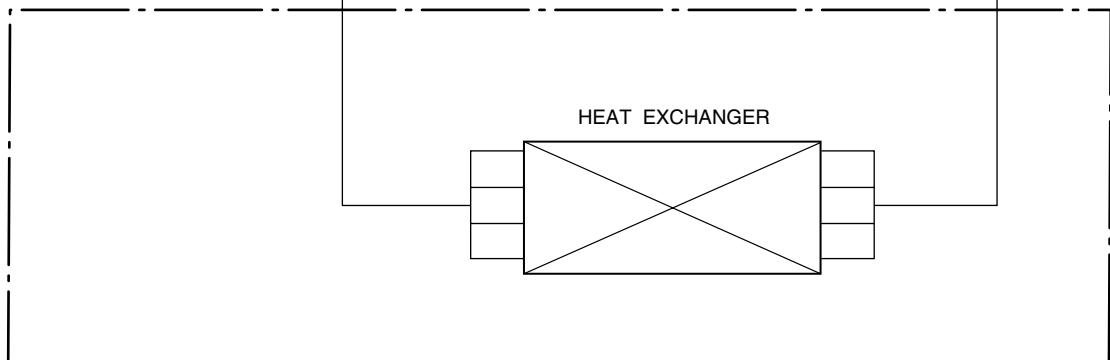

ERROR CONTENTS

The OPERATION, TIMER and SWING lamps operate as follows according to the error contents.

Error contents	Error display		
	OPERATION (RED)	TIMER (GREEN)	SWING (ORANGE)
Indoor unit circuit board error	○	○	—
Indoor unit room temperature sensor wire opened	2 times ●	○	—
Indoor unit room temperature sensor wire short circuited	2 times ●	○	○
Indoor unit piping sensor wire opened	3 times ●	○	—
Indoor unit piping sensor short circuited	3 times ●	○	○
Serial error	5 times ●	○	—
Outdoor unit circuit board error or miswiring between outdoor unit and indoor unit	5 times ●	○	○
Indoor unit fan error	6 times ●	○	—
Outdoor unit piping sensor	○	3 times ●	—
Outdoor unit outdoor temperature sensor error	○	4 times ●	—
Outdoor unit discharge temperature sensor error	○	5 times ●	—
Outdoor unit compressor temperature sensor error	○	9 times ●	—
IPM error	○	10 times ●	—
Current transformer error	○	11 times ●	—
Active filter module error	○	12 times ●	—
Compressor location error	○	13 times ●	—
Outdoor fan motor error	○	14 times ●	—

○ : Fast flashing ● : Slow flashing — : Off

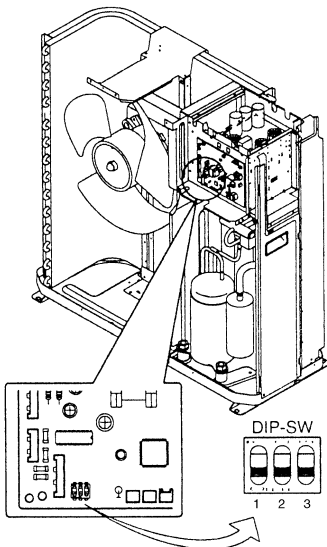

DIP switch

DIP-SW			Current (Max.)	Model
1	2	3		
OFF	OFF	OFF	16.5A	AOH30LMAL
ON	OFF	OFF	14.5A	AOH24LMAL
OFF	ON	OFF	12.0A	
ON	ON	OFF	9.5A	

CIRCUIT DIAGRAM

Models : AWH24LBAJ / AOH24LMAL
AWH30LBAJ / AOH30LMAL

INDOOR UNIT

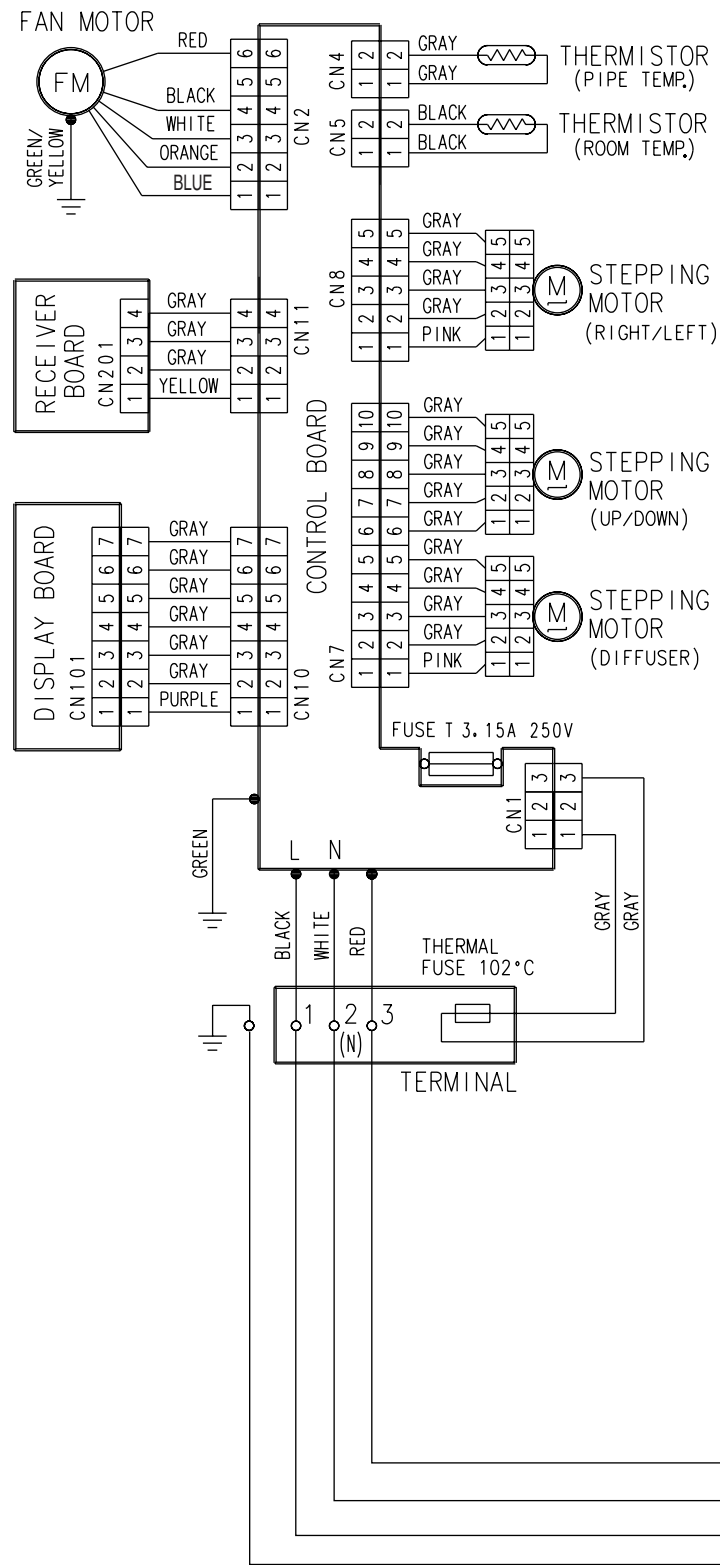

OUTDOOR UNIT

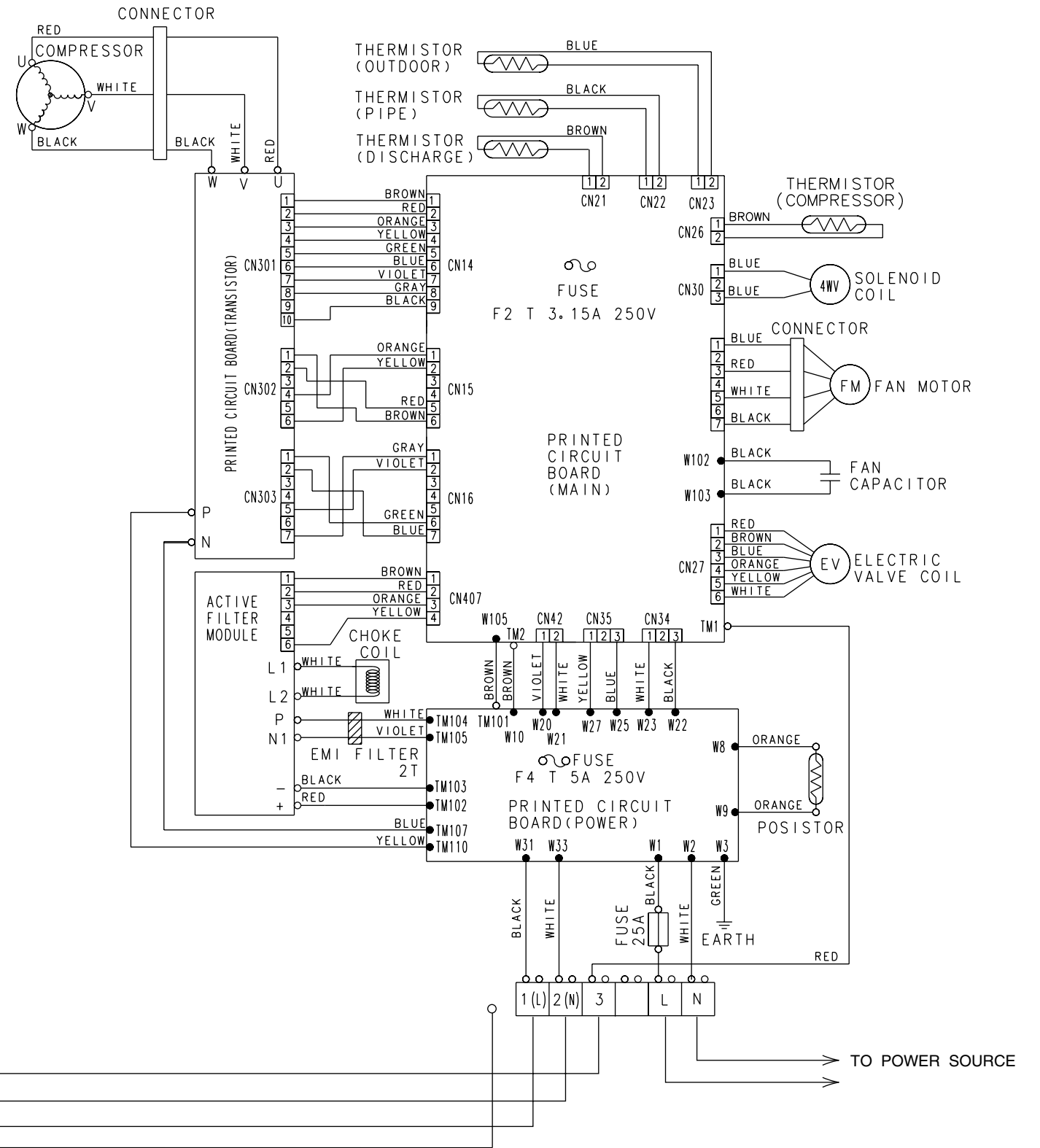

INDOOR PRINTED CIRCUIT BOARD CIRCUIT DIAGRAM

Models : AWH24LBAJ
AWH30LBAJ

CONTROLLER PCB ASSEMBLY (MAIN PCB)
AWY24LBAJ : EZ-0021HHSE-C
AWY30LBAJ : EZ-0021GHSE-C

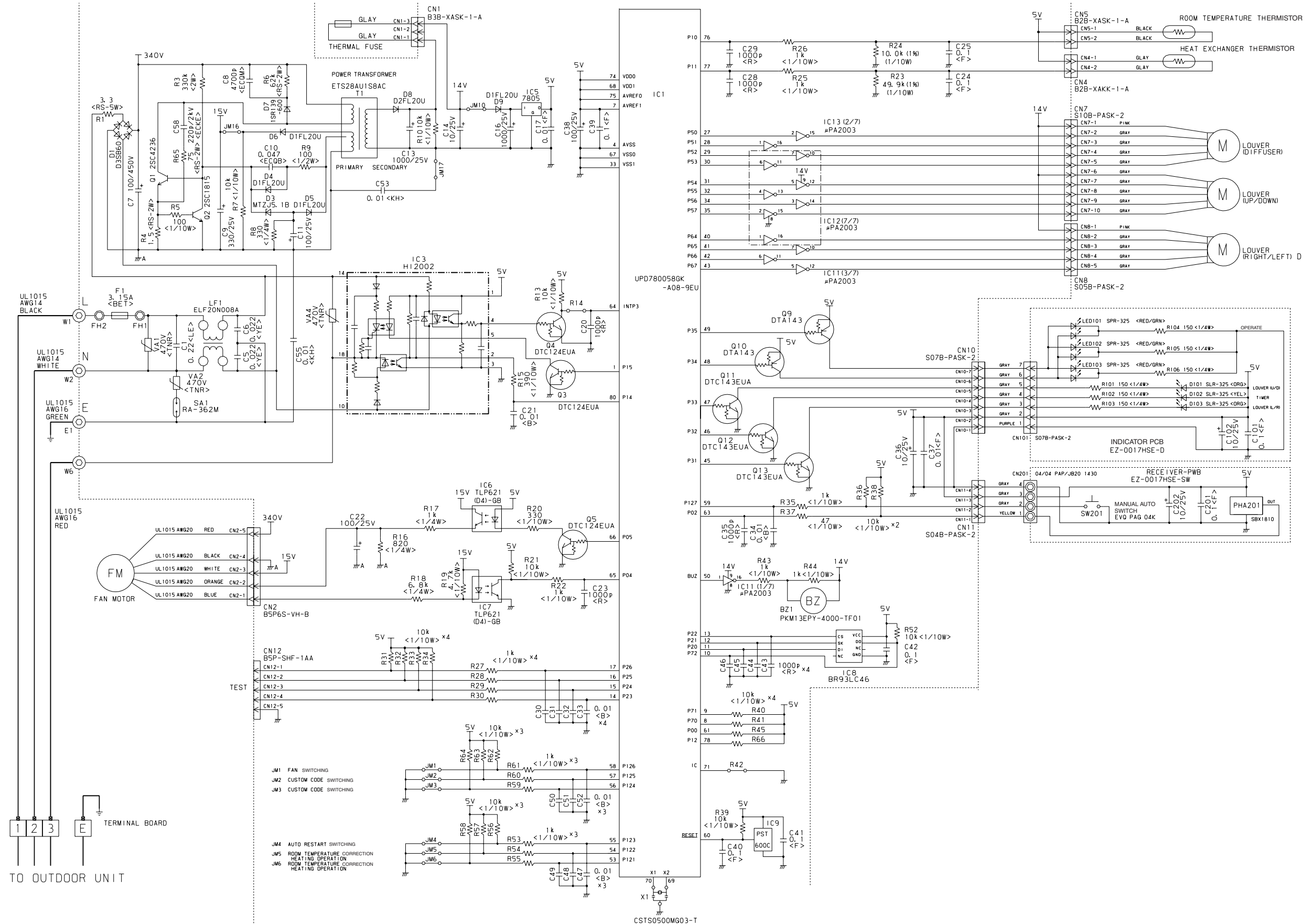

OUTDOOR PRINTED CIRCUIT BOARD CIRCUIT DIAGRAM

Models : AOH24LMAL
AOH30LMAL

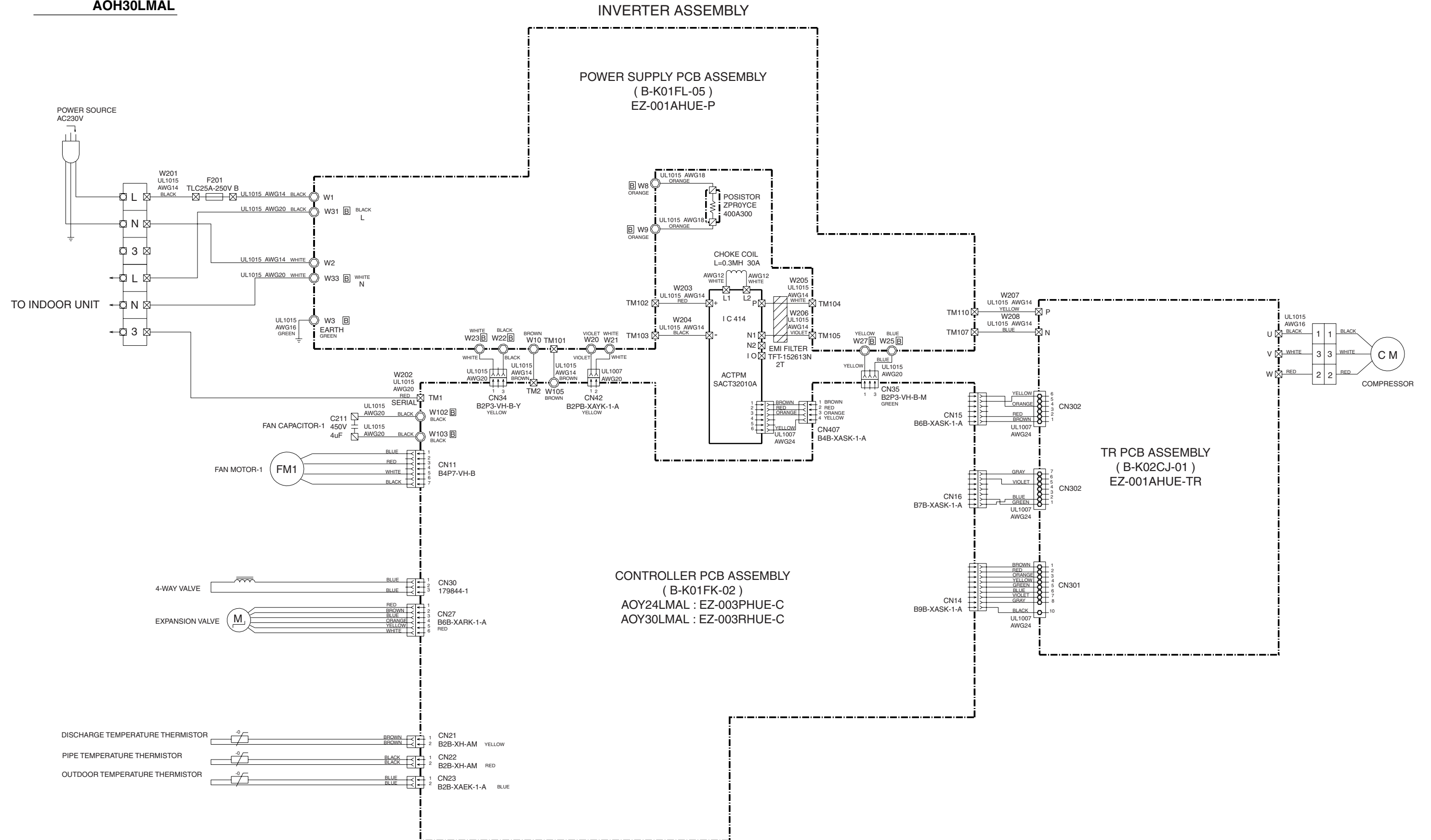

CONTROLLER PCB ASSEMBLY
 AOY24LMAL : EZ-003PHUE-C
 AOY30LMAL : EZ-003RHUE-C

Models : AOH24LMAL
 AOH30LMAL

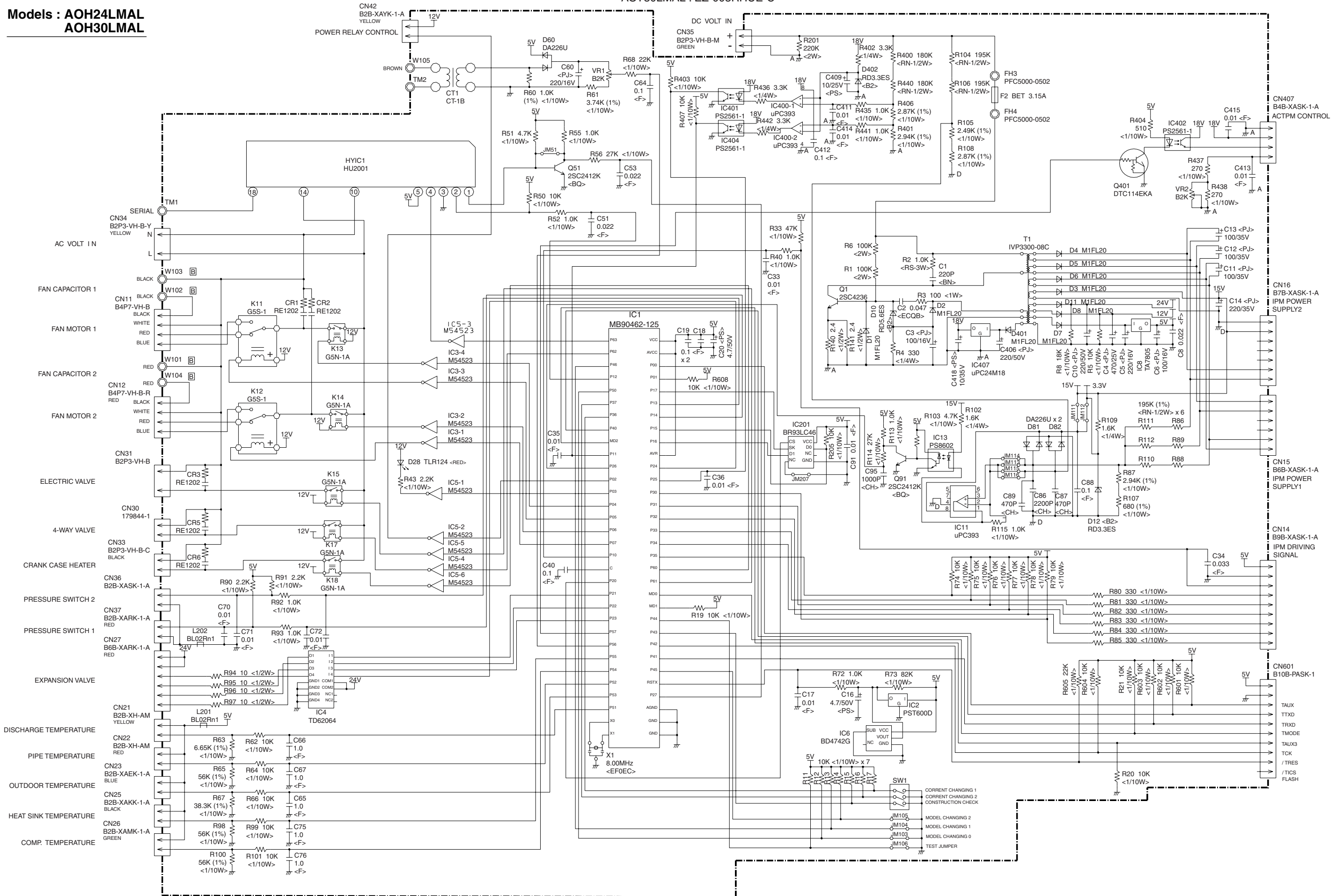

Models : AOH24LMAL
AOH30LMAL

POWER SUPPLY PCB ASSEMBLY
EZ-001AHUE-P

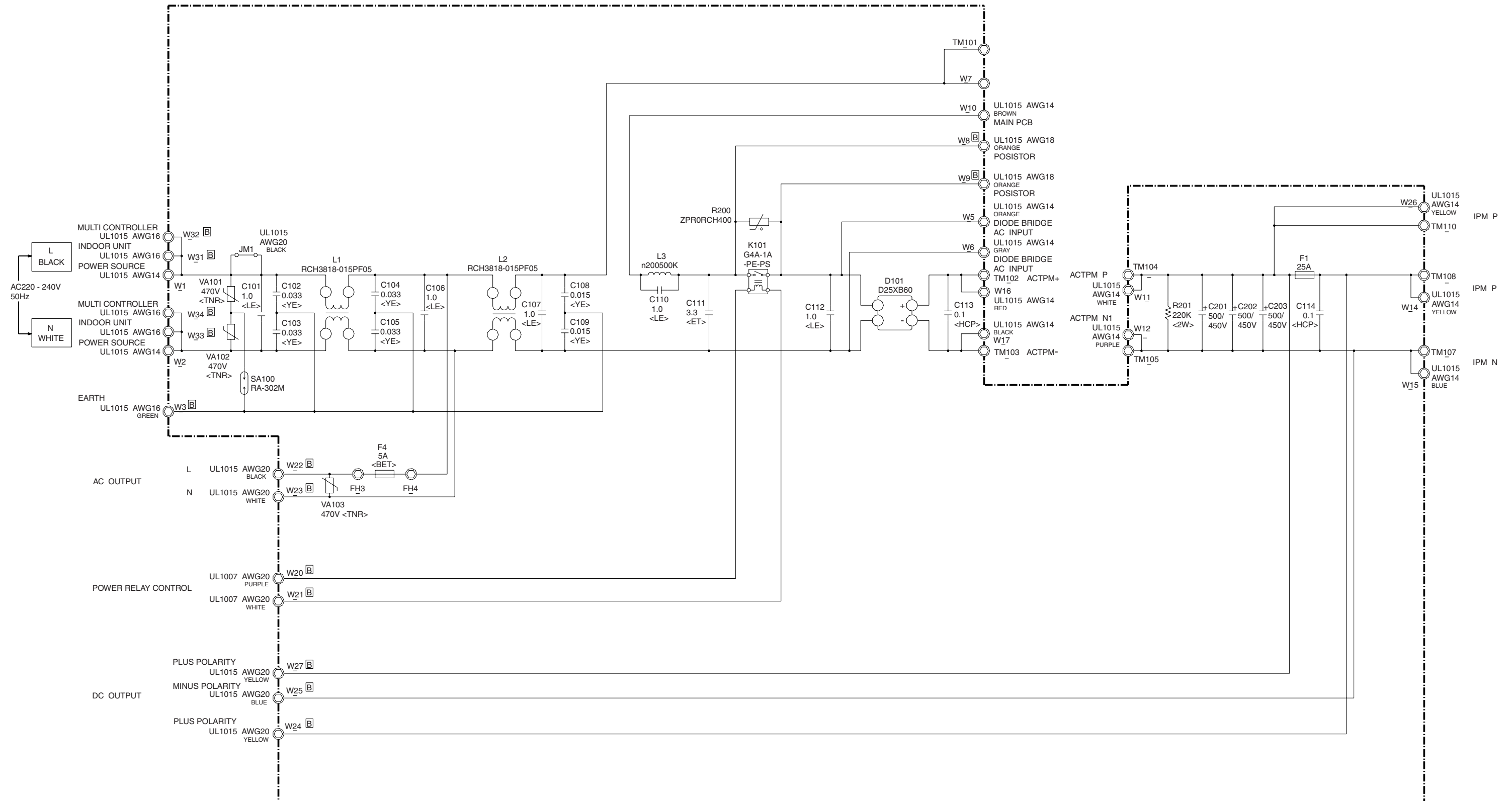

Models : AOH24LMAL
AOH30LMAL

TR PCB ASSEMBLY
EZ-001AHUE-TR

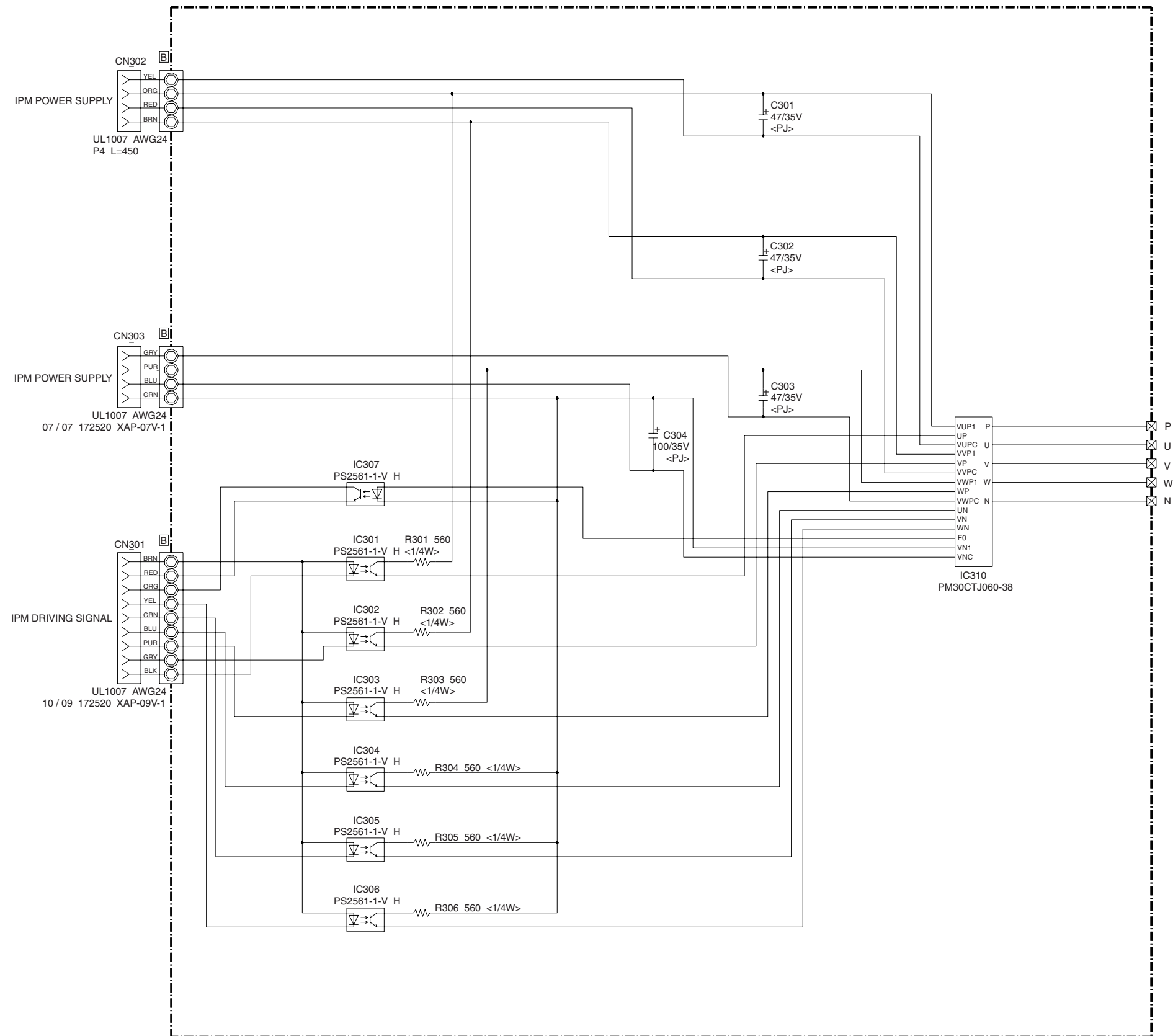

DISASSEMBLY ILLUSTRATION

Models : AWH24LBAJ
AWH30LBAJ

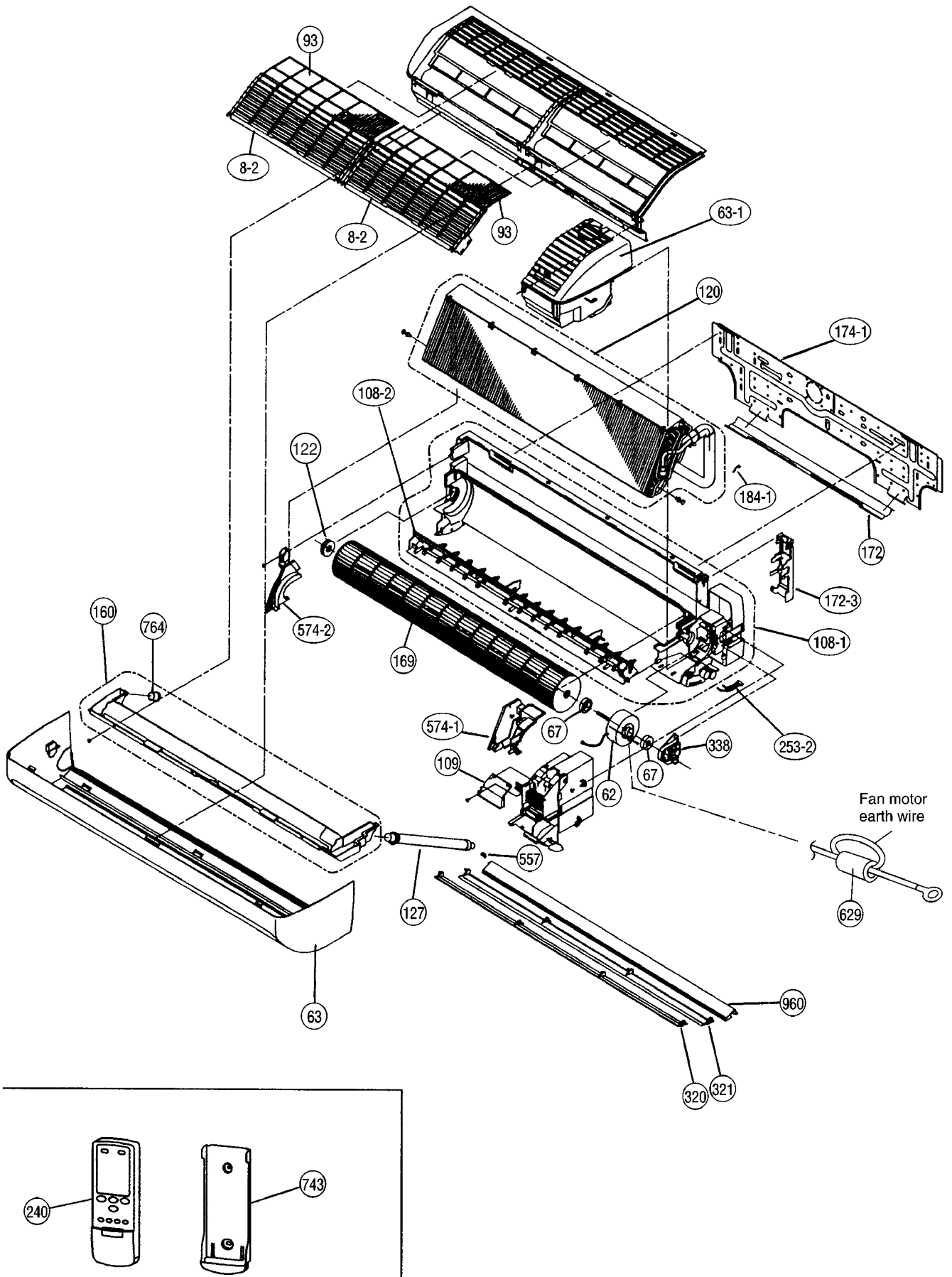

Models : AWH24LBAJ
AWH30LBAJ

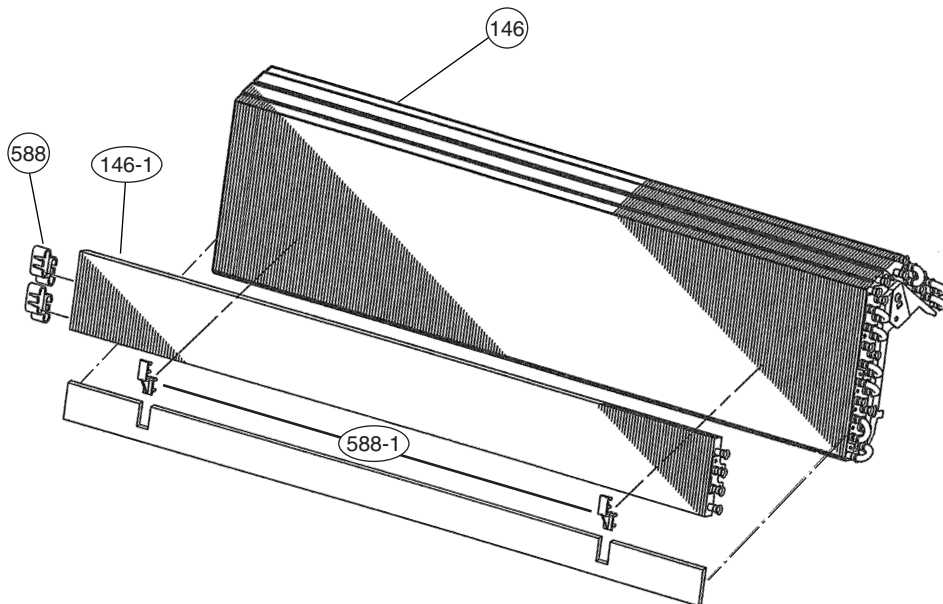
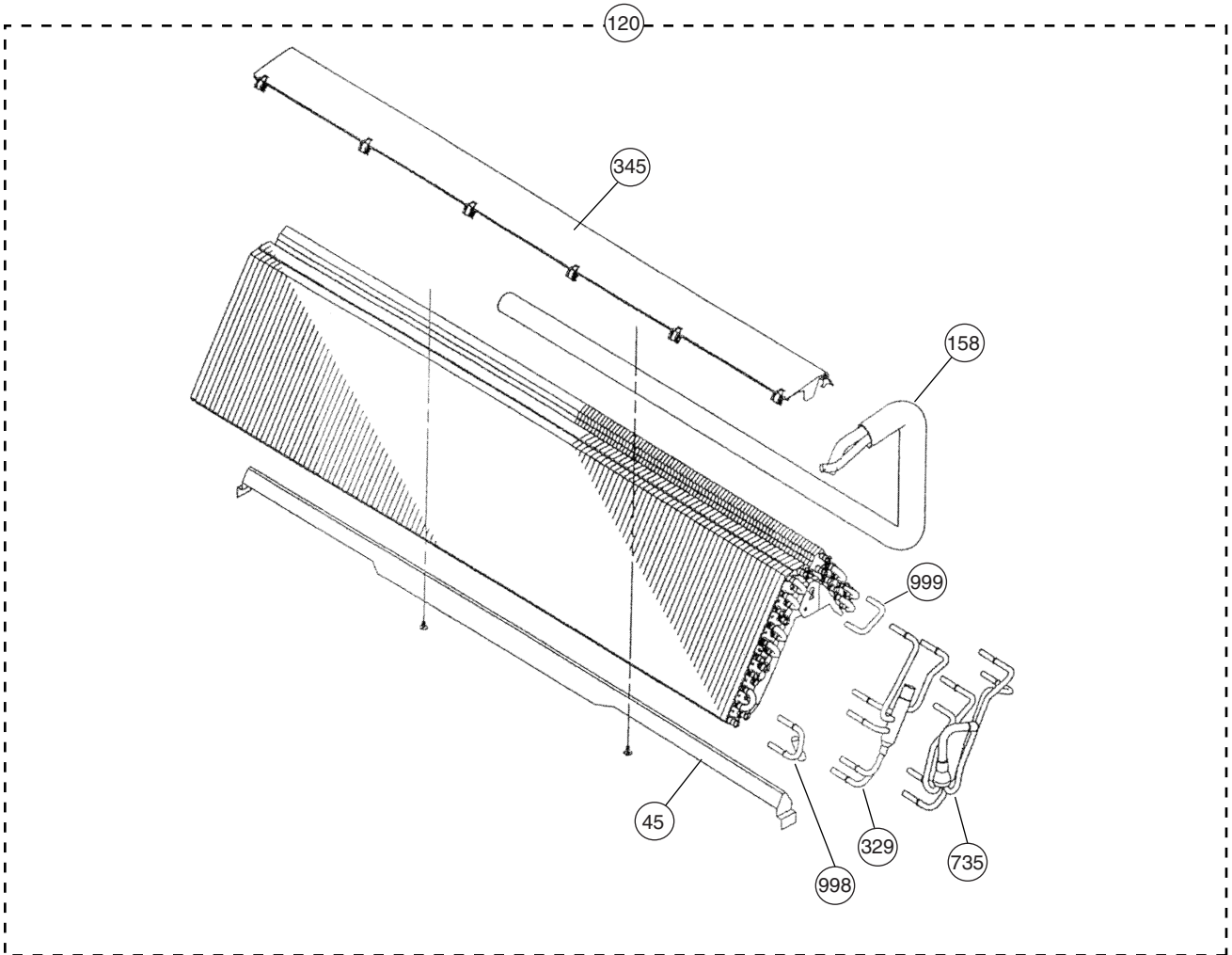

Models : AWH24LBAJ
AWH30LBAJ

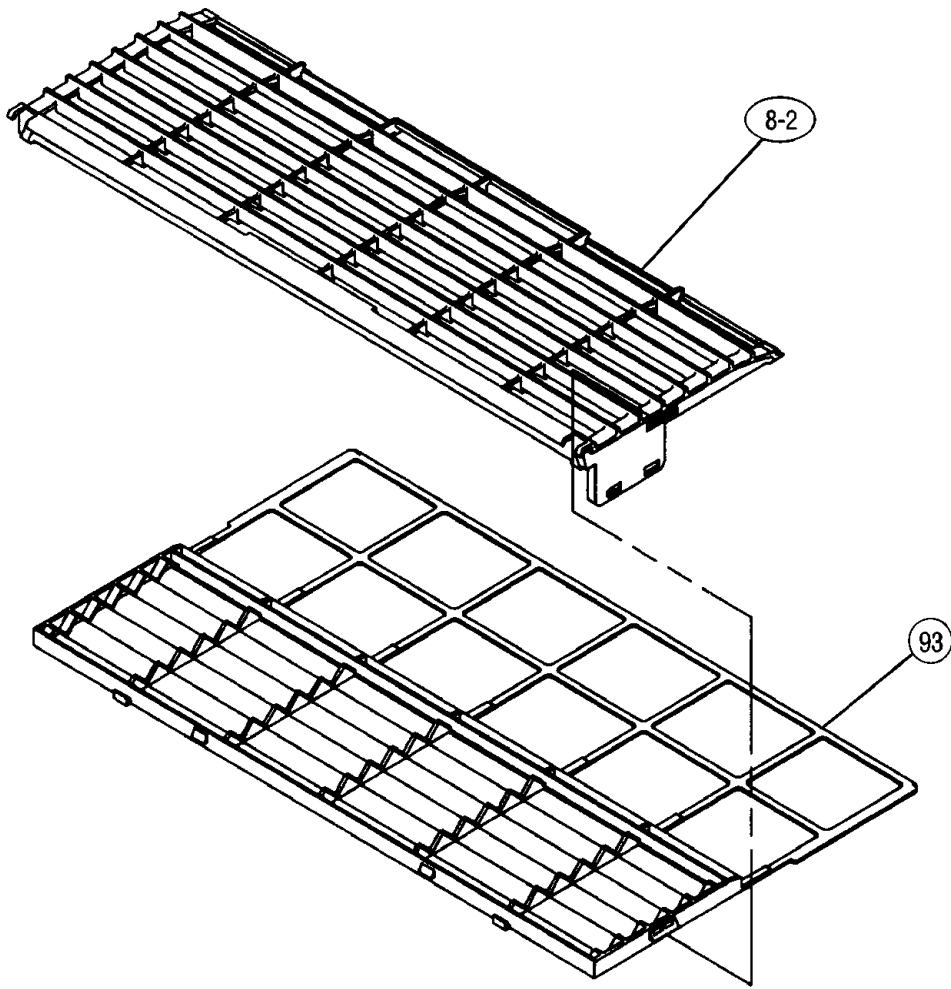

Models : AWH24LBAJ
AWH30LBAJ

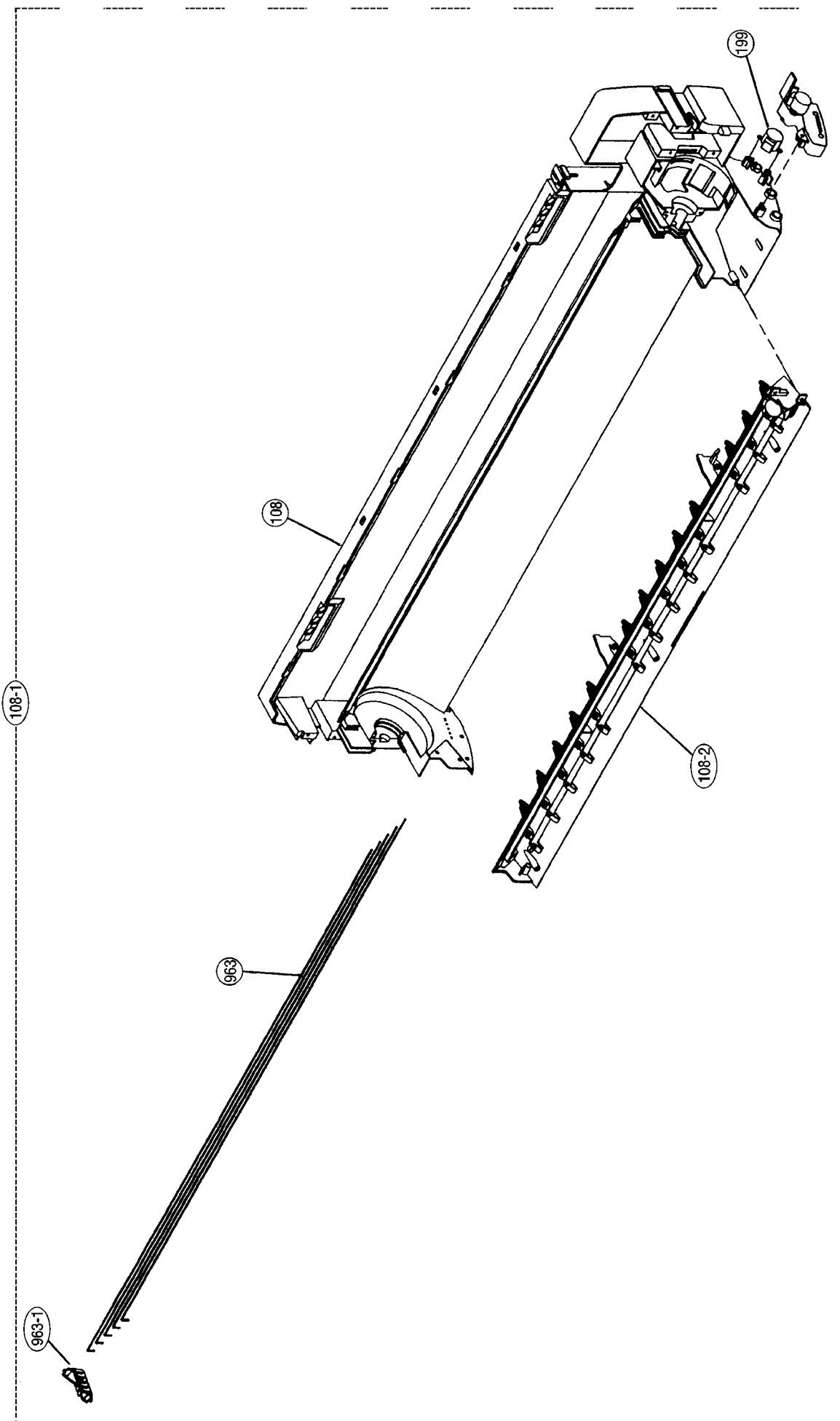

Models : AWH24LBAJ
AWH30LBAJ

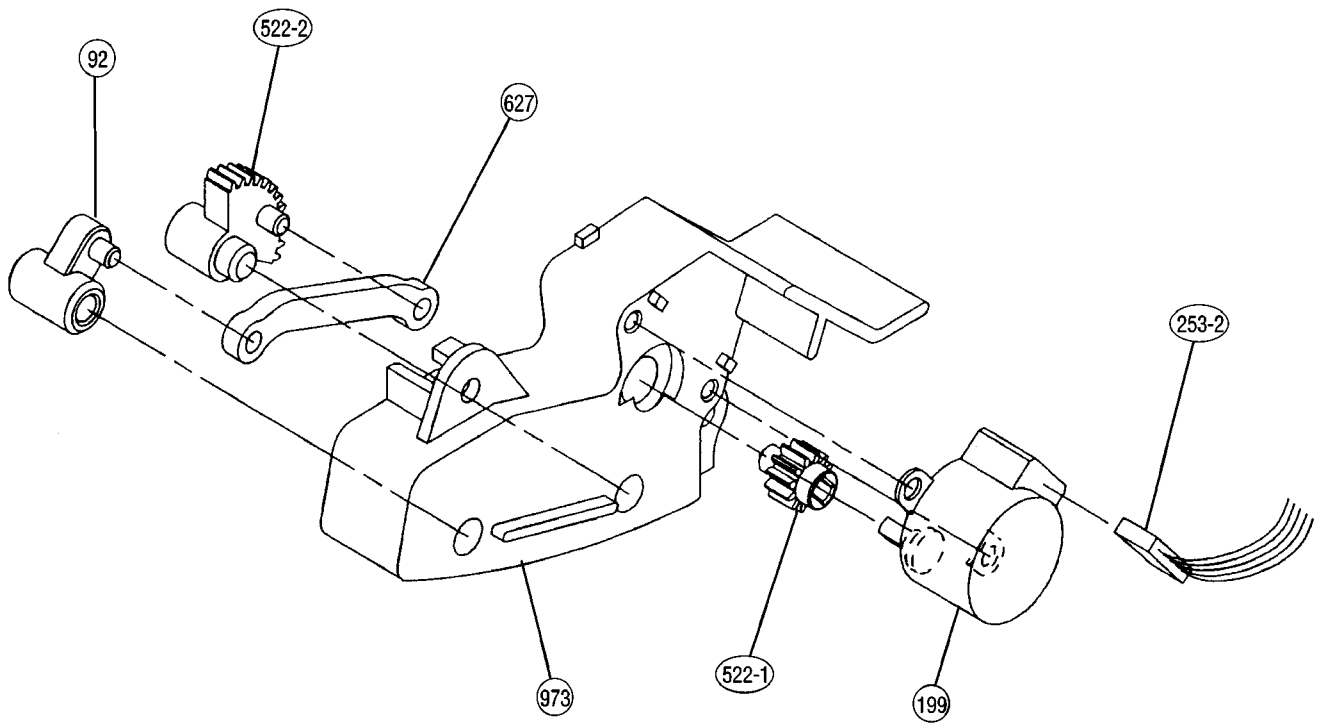

Models : AWH24LBAJ
AWH30LBAJ

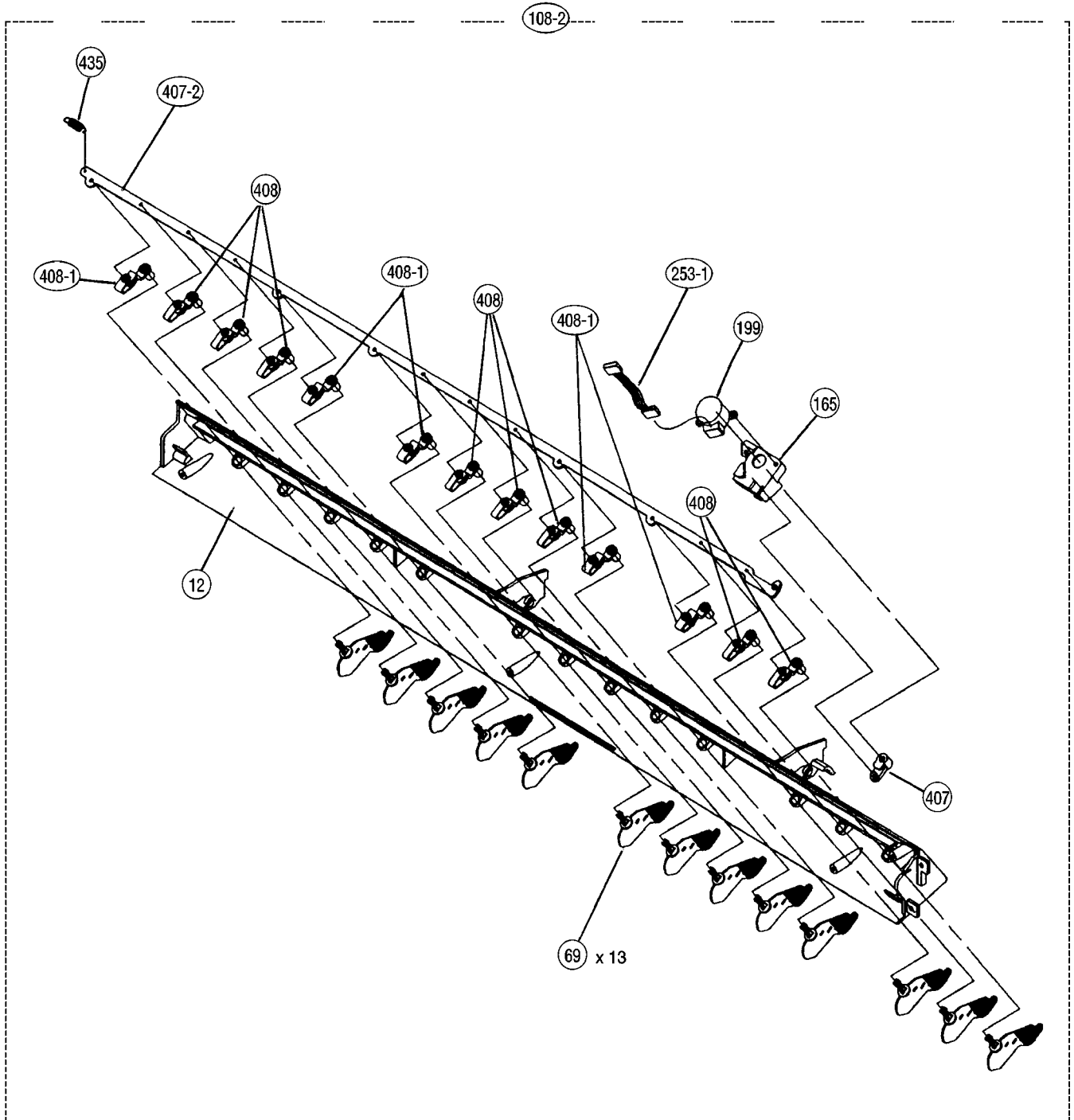

Models : AWH24LBAJ
AWH30LBAJ

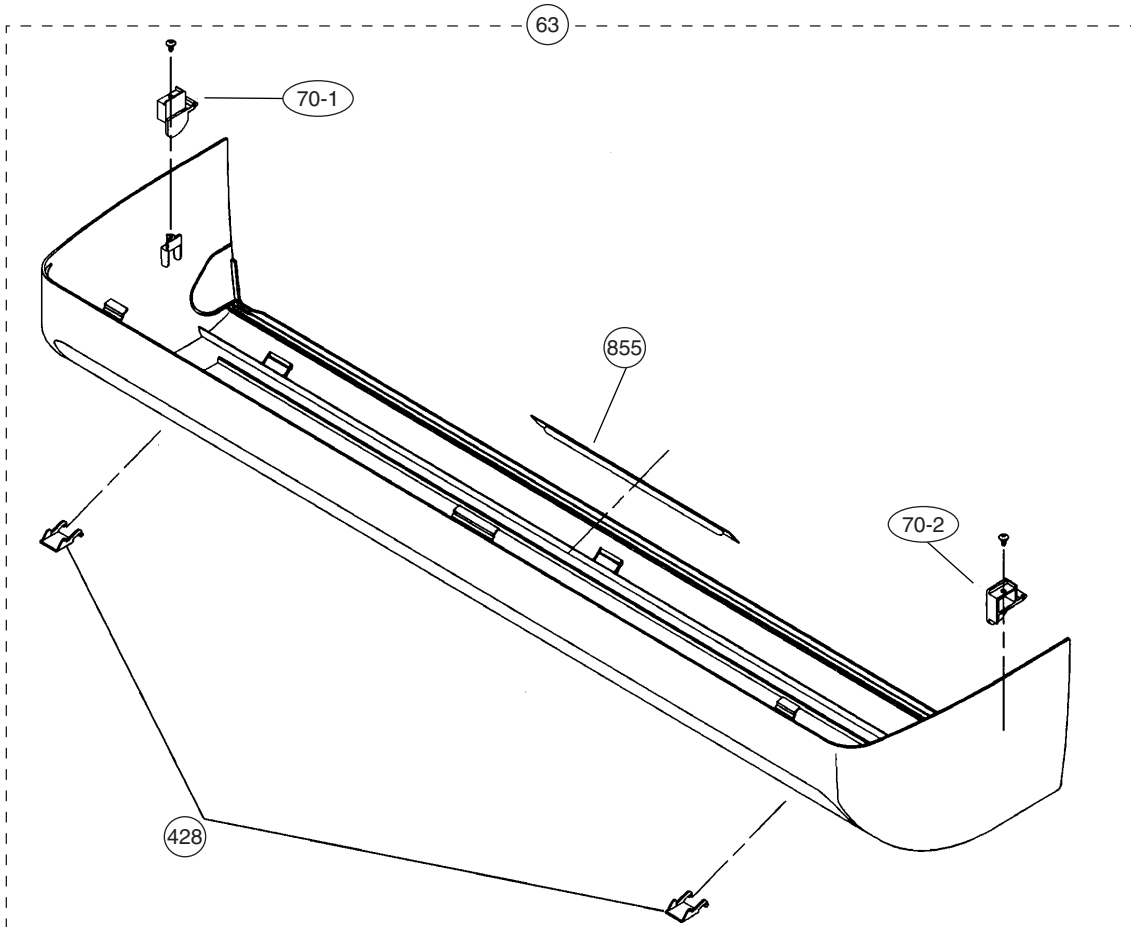
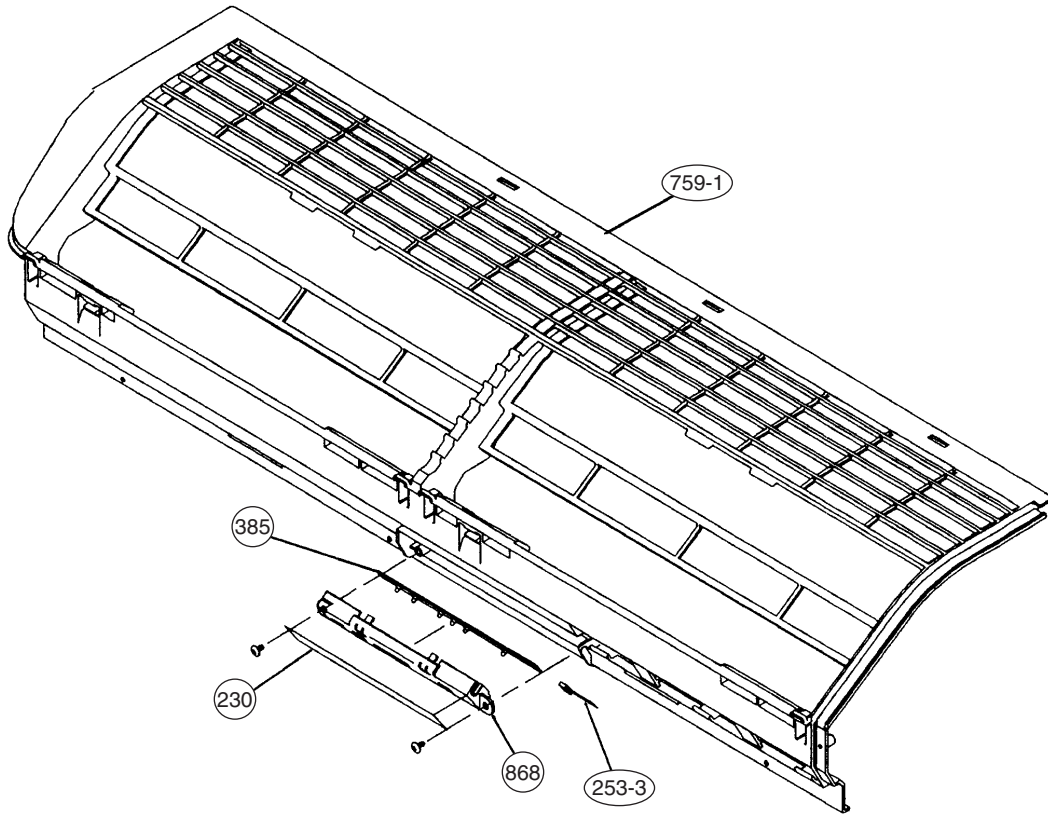

Models : AWH24LBAJ
AWH30LBAJ

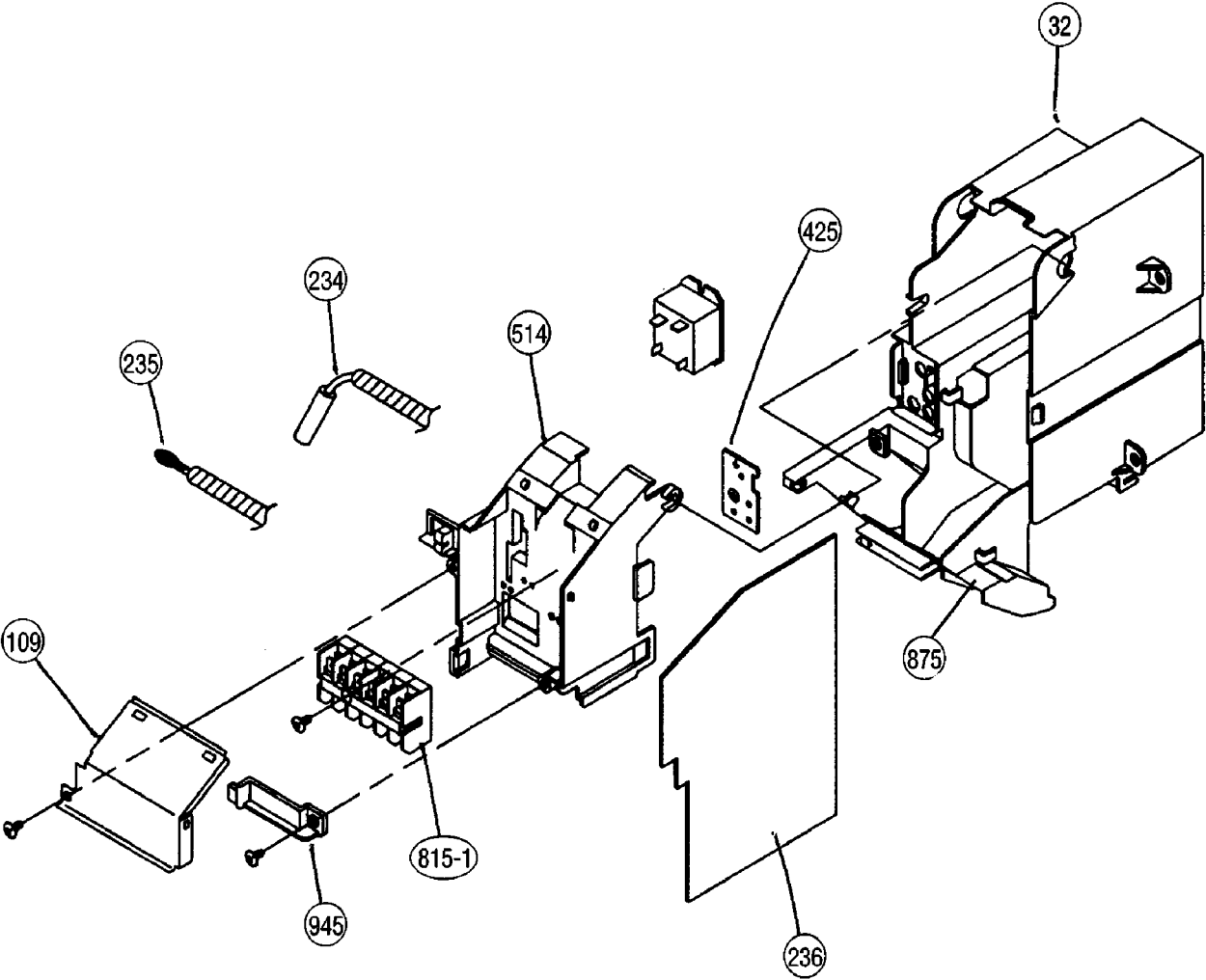

Models : AOH24LMAL
AOH30LMAL

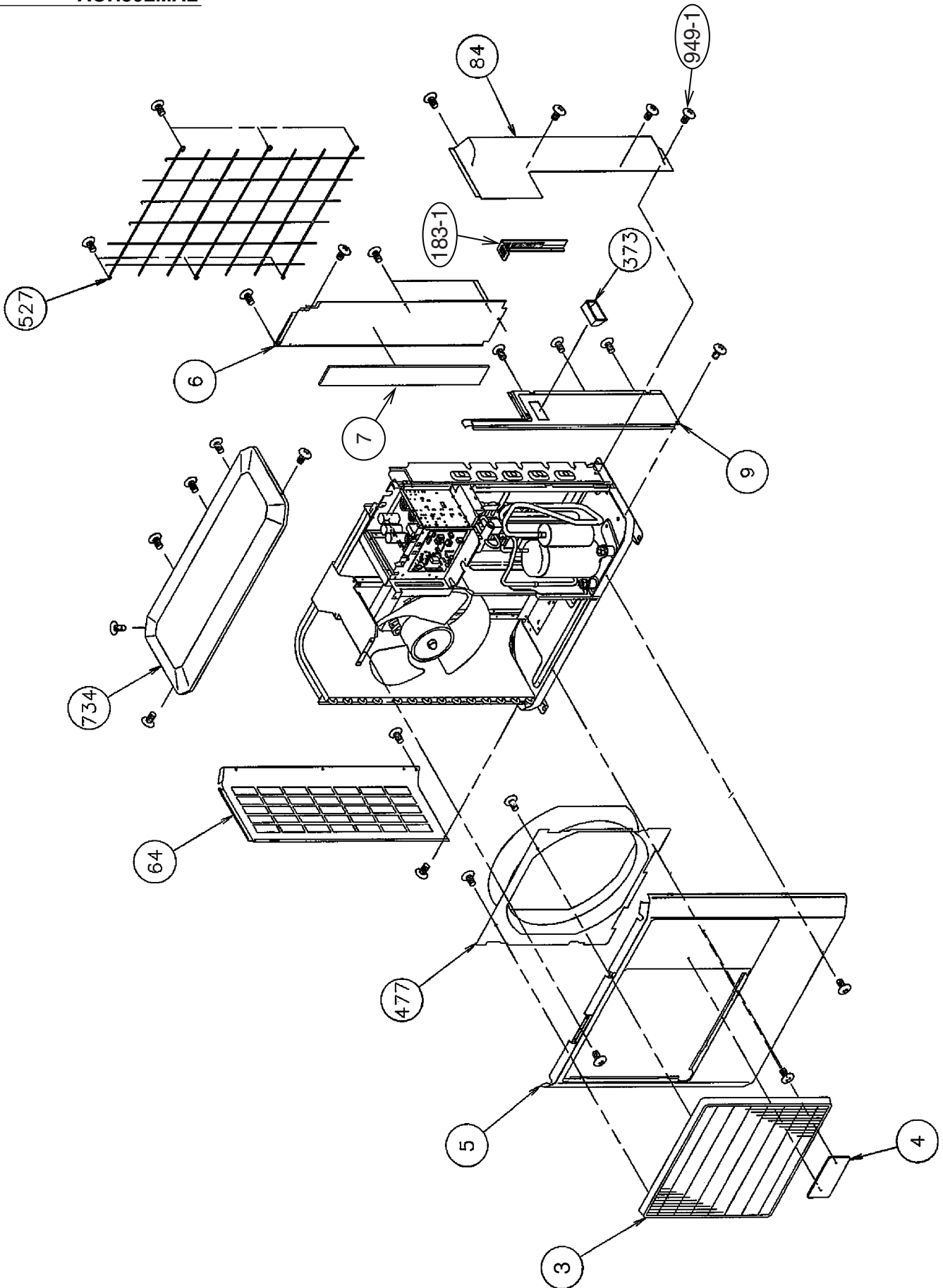

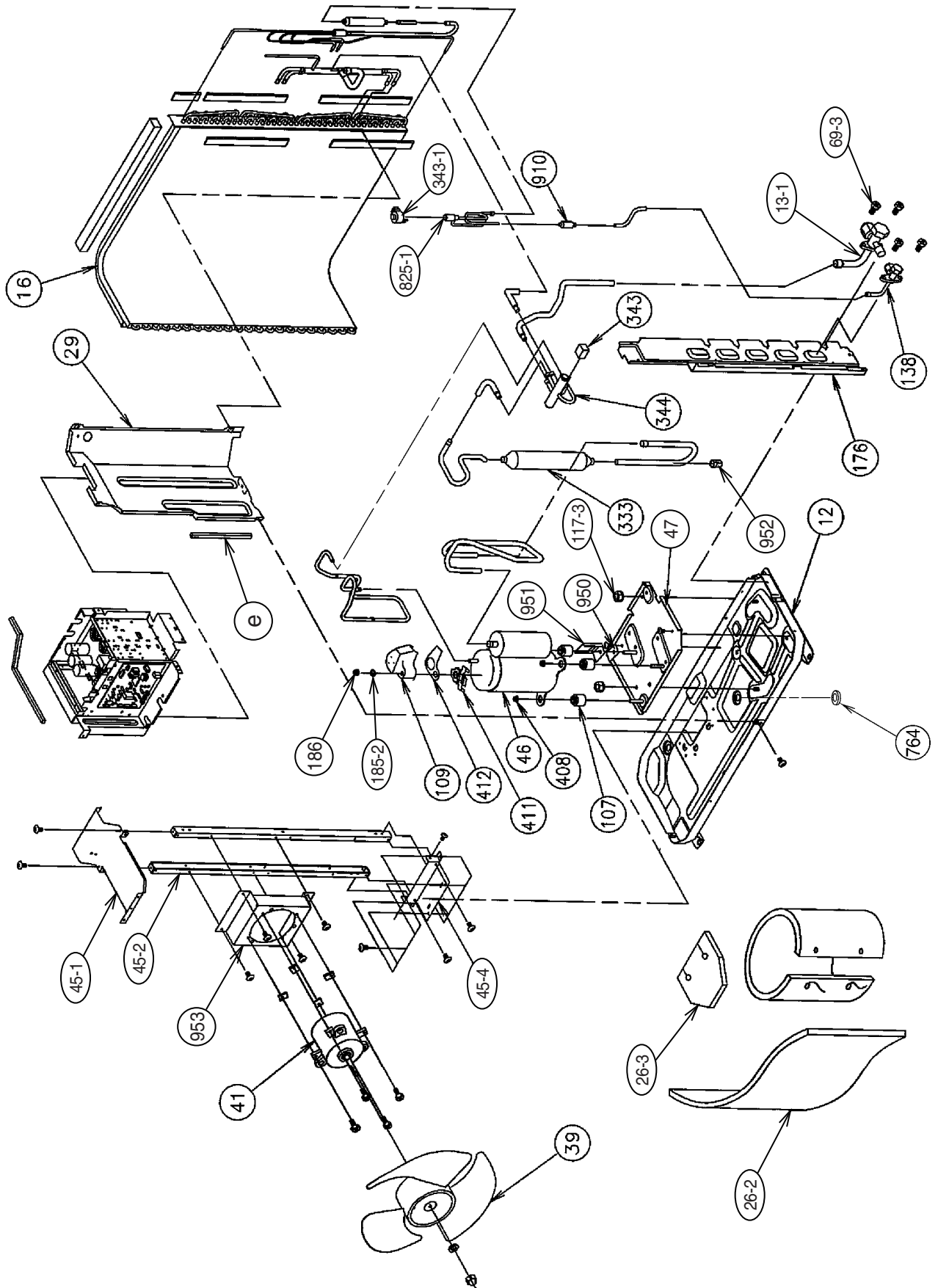

**Models : AOH24LMAL
AOH30LMAL**

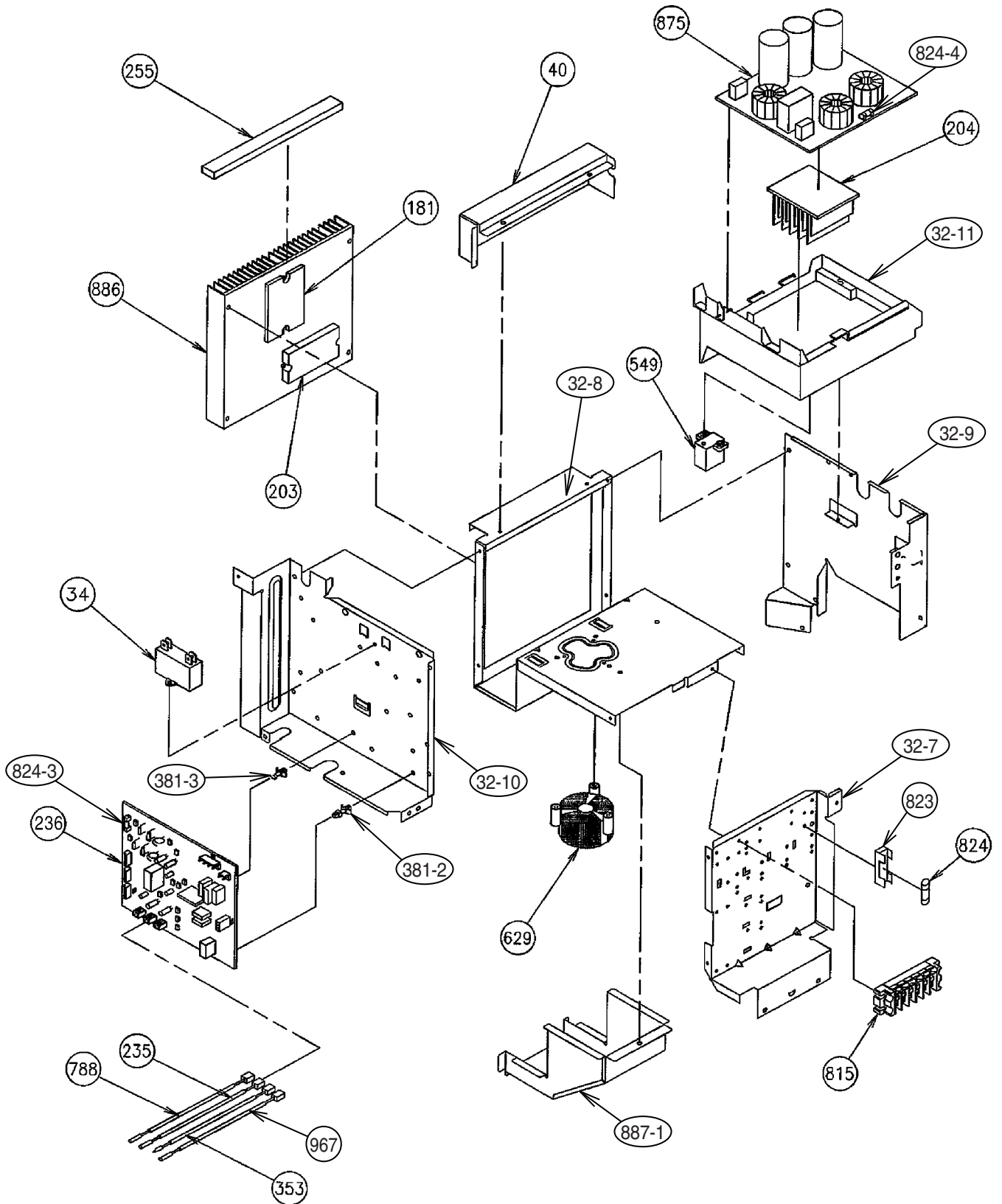

PARTS LIST

INDOOR UNIT

When you order parts, please make a photocopy of this page and fill the number of the parts in the "Order" column.

Ref. No.	Description	Part No.		Ord. Q'ty	Ref. No.	Description	Part No.		Ord. Q'ty
		AWH24LBAJ	AWH30LBAJ				AWH24LBAJ	AWH30LBAJ	
8-2	Filter Frame	9367681013	9367681013		321	Lower Flap	9367689019	9367689019	
12	Base-B	9368216016	9368216016		329	Coupling Pipe Assy	9370561005	9370561005	
32	Control Box	9367663002	9367663002		338	Motor Holder	9367798001	9367798001	
45	Bracket (Eva.) Assy	9369317019	9369317019		345	KIT (FILTER GUIDE)	9371130019	9371130019	
62	Fan Motor-Inner	9601385028	9601385028		385	Indicator PCB Assy	9704368010	9704368010	
63	KIT (Front Cover)	9371132105	9371132105		407	Motor Link	9367696000	9367696000	
63-1	Service Cover Assy	9368837013	9368837013		407-2	Louver Rod	9367698004	9367698004	
67	Rubber (Motor)	9367676002	9367676002		408	Louver Link	9367697007	9367697007	
69	Louver	9367706013	9367706013		408-1	Louver Link-B	9368789008	9368789008	
70-1	Hook (Cover)-L	9367675012	9367675012		425	Earth Plate	9368017002	9368017002	
70-2	Hook (Cover)-R	9367674015	9367674015		428	Screw Cover	9367717019	9367717019	
92	Link Arm	9367694006	9367694006		435	Louver Spring	9369030000	9369030000	
93	Filter	9367680016	9367680016		514	Control Box Cover	9367664009	9367664009	
108	Base	9367683017	9367683017		522-1	Gear-A	9367691005	9367691005	
108-1	Base Assy	9368829056	9368829049		522-2	Gear-B	9367692002	9367692002	
108-2	Base-B Sub Assy	9368843014	9368843014		557	Spring (Diffuser)	9368824006	9368824006	
109	Terminal CVR	9368022006	9368022006		574-1	Eva. Support-R	9367684007	9367684007	
120	Eva. Sub Assy	9368832070	9368832056		574-2	KIT (Eva. Support-L)	9371129013	9371129013	
122	Rub (Bearing) Assy	9368998004	9368998004		588	Eva. Holder	9367711000	9367711000	
127	Drain Hose	9367695003	9367695003		588-1	Eva. Holder-B	9368783006	9368783006	
146	Evaporator Assy	9371999012	9371999012		627	Link	9367693009	9367693009	
146-1	Evaporator Assy-B	9369124006	9369124006		629	EMI Filter	0400056133	0400056133	
158	Joint Pipe Assy	9369144004	9369144004		735	Distributor Assy	9370560008	9370560008	
160	Drain Pan Assy	9368835026	9368835019		743	Remote Control Holder	9305642014	9305642014	
165	Motor Box	9367718009	9367718009		759-1	Intake Cover	9367678013	9367678013	
169	Cross Fan Assy	9367708000	9367708000		764	Drain Cap	9367677009	9367677009	
172	Pipe Bracket	9367844005	9367844005		815-1	Terminal-3P	9306489090	9306489090	
172-3	KIT (Pipe Holder)	9371135014	9371135014		855	Display-G	9367673018	9367673018	
174-1	Fixing Plate	9367987009	9367987009		868	PWB Holder (Display)	9371131016	9371131016	
184-1	Thermo. Spring-A	313728262708	313728262708		875	PCB Assy-Switch	9704370013	9704370013	
199	Step Motor	9900020019	9900020019		945	Wire Holder	9368016005	9368016005	
230	Diffusion Sheet	9368006013	9368006013		960	Diffuser Assy	9368840013	9368840013	
234	Thermistor Assy-Room	9703299148	9703299148		963	Fan Guard	9368015008	9368015008	
235	Thermistor Assy-Pipe	9703297038	9703297038		963-1	Fan Guard Holder	9367707003	9367707003	
236	Controller PCB Assy	9705066021	9705066014		973	Gear Box	9367690008	9367690008	
240	Remote Control Unit	9371190112	9371190112		998	Bypass Pipe-B Assy	9372000014	9372000014	
253-1	Wire With Connector	9704434012	9704434012		999	Bypass Pipe	9369126000	9369126000	
253-2	Wire With Connector	9704435019	9704435019						
253-3	Wire With Connector	9704433015	9704433015						
320	Upper Flap	9367688012	9367688012						

OUTDOOR UNIT





When you order parts, please make a photocopy of this page and fill the number of the parts in the "Order" column.

Ref. No.	Description	Part No.		Ord. Q'ty	Ref. No.	Description	Part No.		Ord. Q'ty
		AOH24LMAL	AOH30LMAL				AOH24LMAL	AOH30LMAL	
3	Fan Guard	9371187013	9371187013		235	Thermo.(Heat Exchi)	9704220059	9704220059	
4	Emblem-Rear	313791088308	313791088308		236	Controller PCB Assy	9704719072	9704719089	
5	Cabinet-A, Painted	9359797029	9359797029				(EZ-003PHUE-C)	(EZ-003RHUE-C)	
6	Cabinet-C, Painted	9363798029	9363798029		255	Insulation (Heat Sink)	9370844009	9370844009	
7	Noise Ins A	9370181005	9370181005		333	Accumulator	9351997014	9351997014	
9	Cabinet-B	9363797022	9363797022		343	Solenoid	9900165024	9900165024	
12	Base Assy, Painted	9364145020	9364145020		343-1	Coil (EXP Valve)	9970006012	9970006012	
13-1	3-Way Valve Assy	9372205075	9372205075		344	4-way Valve	9900163013	9900163013	
16	Condenser Assy	9373254010	9373254010		353	Thermistor Assy-Out	9703516054	9703516054	
26-2	Compressor Cover-B	9372067017	9372067017		373	Grip	9352157004	9352157004	
26-3	Compressor Cover-C	9370186000	9370186000		381-2	Locking Spacer	0600035020	0600035020	
29	Separate Wall-B	9369625015	9369625015		381-3	Locking Spacer	0600118051	0600118051	
32-7	Control Box Metal-G	9369616006	9369616006		408	Special Nut M8	9355091008	9355091008	
32-8	Control Box Metal-H	9369617003	9369617003		411	Holder	9372066010	9372066010	
32-9	Control Box Metal-I	9369618000	9369618000		412	Terminal Packing	9370290004	9370290004	
32-10	Control Box Metal-J	9369619007	9369619007		477	Bell-Mouth	9359809012	9359809012	
32-11	Control Box-K	9369620010	9369620010		527	Protectine Net	9359844013	9359844013	
34	Capacitor (Fan Motor)	9704305015	9704305015		549	PTC Thermistor	9704265012	9704265012	
39	Propeller Fan	9359837015	9359837015		629	Coil, Choke	9703458019	9703458019	
40	Air seal Plate	9369623004	9369623004		734	Cabinet Top Plate	9359799023	9359799023	
41	Fan Motor Assy Out	9601754015	9601754015		764	Drain Cap	313166024302	313166024302	
45-1	Motor Bracket-A	9369627002	9369627002		788	Thermistor (Disc Temp.)	9704219077	9704219077	
45-2	Motor Bracket-B	9369628009	9369628009		815	Terminal-6P	9358660089	9358660089	
45-4	Motor Bracket-D	9369630002	9369630002		823	Fuse Holder	0500158072	0500158072	
46	Compressor Assy	9373531012	9373531012		824	Fuse	0600086039	0600086039	
47	Comp Plate Assy	9363800005	9363800005		824-3	Fuse	0600222512	0600222512	
64	Cabinet Left.	9359840022	9359840022		824-4	Fuse	0600222529	0600222529	
69-3	Bolt, Hex.Socket	301210060360	301210060360		825-1	EXP Valve Assy	9373251019	9373251019	
84	Valve Cover	9363802009	9363802009		875	Filter PCB Assy	9704722010	9704722010	
107	Rubber Seat-A	9358080009	9358080009		886	Heat Sink-A	9369792007	9369792007	
109	Terminal Cover	9370289008	9370289008		887-1	Reactor Cover	9369622007	9369622007	
117-3	Hex. Nut w/SP. Washer	301721180114	301721180114		910	Strainer-B	9365099018	9365099018	
138	2-Way Valve Assy	9372204061	9372204061		949-1	Screw , Painted	9305648009	9305648009	
176	Valve Fixing Plate-A	9363799064	9363799064		950	Accum Support Sheet	9354022010	9354022010	
181	ACTPM	9703457012	9703457012		951	Accum SPT AS	313986353804	313986353804	
183-1	Water Seal Plate-B	9369626012	9369626012		952	Acum HLD Rub	9354022010	9354022010	
185-2	Rubber Washer	9358078006	9358078006		953	Motor Bracket CTR	9373076018	9373076018	
186	Frange nut	9358079003	9358079003		967	Comp Temp Thermo.	9900156015	9900156015	
203	TR PCB Assy	9704009029	9704009029		e	Seperate Wall Ins B	9360074201	9360074201	
204	Heat Sink-B	9369793004	9369793004		----	Capacitor	9704729019	9704729019	



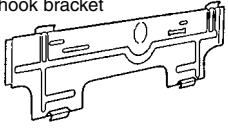
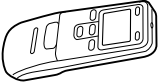

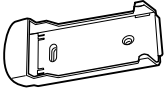
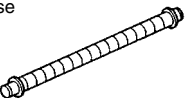
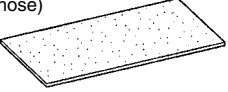
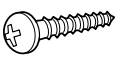
STANDARD ACCESSORIES

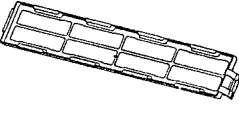
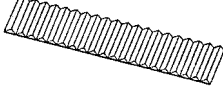
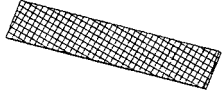
Models : AWH24LBAJ / AOH24LMAL
 AWH30LBAJ / AOH30LMAL

INDOOR UNIT ACCESSORIES

Name and Shape	Part No.
Wall hook bracket 	9367987009
Remote control unit 	9371190112 (AR-JW11)
Battery (penlight) 	0600185534
Remote control unit holder 	9305642012
Drain hose 	9367695003
Insulation (Drain hose) 	9361756007
Tapping screw (big) (ø 4 x 20) 	301141164200
Tapping screw (small) (ø 3 x 12) 	301141533125
Holder 	The holders are attached to the filter frames of the indoor unit. 9367719006
Air purifying filter 	9370528022
Deodorizing filter 	9370527025

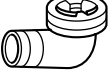
OUTDOOR UNIT ACCESSORIES

Name and Shape	Part No.
Hexagon wrench 	9351228019
Cable clip 	313739340109
Tapping screw 	301463040100
Drain pipe 	9303029015
Drain cap 	313166024302
Putty 	303020200114

SERVICE PARTS

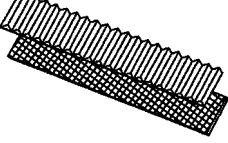
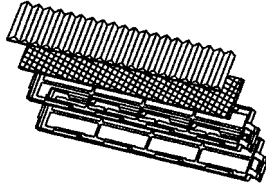
Name and Shape	Part No.
Service electric filter 	UTR-FB11
Optional electric filter 	UTR-FA11

